

## The Oxygenator

The Oxygenator is used to efficiently provide aeration to an aerobic wastewater treatment basin. Conventional aerators utilize atmospheric air to dissolve oxygen into the water so that the microorganisms can consume the BOD in the wastewater. These conventional aerators require significant surface area compared to their relatively low oxygen transfer rates. The Oxygenator does not rely on atmospheric air as an oxygen source. Instead the oxygenator delivers near 100 percent pure oxygen to the water. This eliminates the 80 percent of the nitrogen that conventional aerators deliver to the water. The benefits created by using pure oxygen include very high oxygen transfer efficiency and the resulting energy cost savings.

The Oxygenator is capable of delivering a very large amount of oxygen while consuming a very small amount of surface area. The efficient treatment of pounds of BOD per aeration basin surface area is increased compared to conventional aerators. Existing aeration basins can be retrofitted with The Oxygenator to postpone plant expansion for increased capital savings.

The Oxygenator is usually used in conjunction with an Oxygen Flow Controller which controls the flow of Oxygen to The Oxygenator based on the dissolved oxygen levels in the aeration basin. Pure oxygen is typically supplied by a VSA oxygen concentrator or bulk delivery of liquid oxygen.

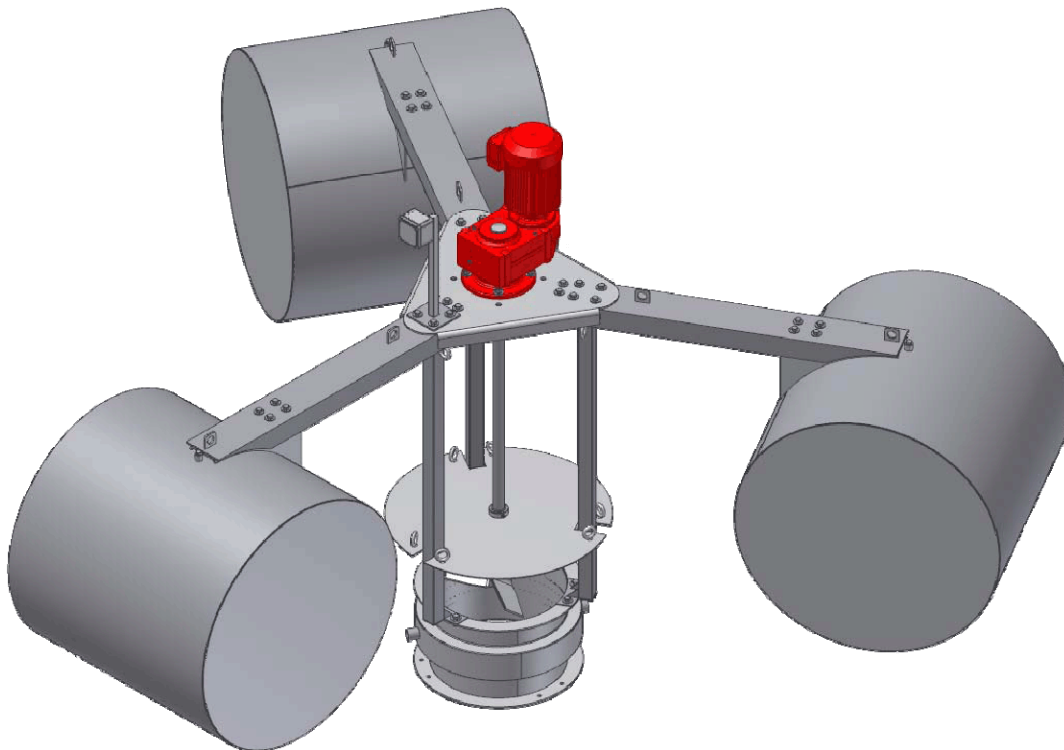

## Typical Aerator Oxygen Transfer Efficiency Rates

Aeration Method	Standard Transfer Efficiency (kg/kWh)
Fine Bubble Diffusers – Air Based	1.2 - 2.0
Medium Bubble Diffusers – Air Based	1.0 – 1.6
Surface Aeration – Air Based	1.2 – 2.4
Jet Aerators – Air Based	1.2 – 2.4
The Oxygenator – O <sub>2</sub> Based	3.8

- Improved Dissolved Oxygen Control:

The use of the oxygen flow controller allows the Oxygenator to precisely control the DO level without impeding the mixing energy in an aeration basin

- Plant Expansion:

The use of pure oxygen allows a sustainable higher biomass in the aeration basin over conventional aeration. This allows the expansion in BOD digestion in an aeration basin by the use the Oxygenator and a VSA

- High Oxygen Transfer Efficiency:

The higher oxygen transfer efficiency of 6lb / hp-hr while dissolving greater than 70% of the oxygen

- Suitable For Shallow Basins

The use of pure oxygen in conjunction with the high efficiency Oxygenator allow the oxygen to efficiently dissolve in shallow basins .

## Typical Oxygenator, Oxygen Flow Controller, and VSA Installation



### The Oxygenator :

- 304 stainless steel construction for a long service life.
- Few moving parts for durability
- Available in 5, 10, and 20 HP
- TEFC severe duty 3 phase motor
- Modular oxygen diffusers for quick service or future expansion